

Confinement Effects on High-Strength Concrete Columns Subjected Eccentric Loading

Antonius

Department of Civil Engineering, Universitas Islam Sultan Agung (UNISSULA), Semarang, Indonesia

Abstract: This paper presents the results of tests of 12 high-strength reinforced concrete columns subjected eccentric loading. The test parameters included the concrete compressive strength (50 to 72 MPa), longitudinal reinforcement ratio, load eccentricities and volumetric ratio of confinement reinforcement. From the test results shows that the ductility of confined concrete tends decreases when the concrete strength increases. A confined concrete model, developed on the basis of column tests under concentric loading, was used to compute analytical moment-curvature relationships. The model are compared with those recorded experimentally. The comparisons indicate that the flexural behaviour of confined concrete columns can be computed reasonably accurately by a confined concrete model.

Keywords: high-strength concrete, confinement, eccentric loading

1 INTRODUCTION

The strength and durability of concrete has undergone continuous improvement over the years and these improved materials are now commonly used. Nowadays, attention in civil engineering is focused on high performance structural materials. The high performance of the material tends to substantial questions concerning not only the bearing capacity, but also its ductility and post-peak behaviour.

The development of concrete technology and practice has led to a changing perception of the definition of high-strength concrete. Current design practices and equations (SNI 03-2847-2002) that are based on experiments on concrete with concrete compressive strength less the 41 MPa. It is convenient, to define an arbitrary lower limit for the definition of high-strength concrete. In this paper, limit of 50 MPa is used to define the lower limit of high-strength concrete.

It is well known that confining concrete with lateral reinforcement increases its strength and ductility in axial compression [Foster & Attard (1997), Mostafaei et al (2009)]. Characteristics of confined concrete have been researched extensively during the last four decades. The main variables considered in these research included in the size, strength, amount and spacing of lateral reinforcement. Many researchers have put a relatively large amount of effort into understanding the confinement mechanism and introducing a suitable model for the behaviour of confined concrete in reinforced concrete elements subjected concentric and eccentric loading. The researchers indicated that the confinement pressure provided by transverse reinforcement would be different under a strain gradient than under uniform

compression. Razvi & Saatcioglu (1999) and Legeron & Paultré (2000) showed that moment-curvature relationships obtained through the confined concrete model developed for concentric compression produced good correlations with envelopes of experimentally obtained moment-curvature hysteretic relationships.

Until last decade, very limited test data is available on high-strength concrete columns subject to eccentric loading. Ibrahim & MacGregor (1996) has conducted tests of 20 eccentrically loaded high-strength and ultra high-strength concrete columns considered main parameter are shape of section (triangular and square). Lloyd and Rangan (1996) has also conducted experimental investigation on the 36 high-strength concrete columns. The parameters on the tests are concrete compressive strength, end of eccentricities and the dimension of the section. Another research has conducted by Tan & Nguyen (2005) where the experimental program on high-strength concrete columns were investigated while objective to evaluate the concrete stress block parameters on high strength concrete.

The present paper summarizes experimental information about the effects of confinement of rectilinear transverse hoops on the high-strength concrete subjected eccentric loading. Tests specimens were made of concrete columns with compressive strength from 50 to 72 MPa The test parameters included of concrete compressive strength, ratio of confining reinforcement, ratio of longitudinal reinforcement and load eccentricities. All the test specimens were tested to large deformation under monotonic axial loading. Also, the applicability of the

stress-strain curve model, proposed by author, to the experimental results is examined.

2 EXPERIMENTAL PROGRAM

2.1 Material properties

Two different mixes were used to develop target cylinder strength of 50 and 70 MPa. Table 1 provides the mix design for different concrete strengths. The sand and coarse aggregate used were from a local pit. The maximum coarse diameter is 14 mm. The Superplasticizer (SP) with type of Sikament NN was used to improved the workability of the concrete mix. Fifteen percent by weight of the Portland cement was repalaced by Fly Ash to produce the high-strength concrete.

Table 1. Mix design of concrete

Materials	f_c' target (50 MPa)	f_c' target (70 MPa)
Cement (Kg/m ³)	419.98	485
Fly Ash (Kg/m ³)	74.11	82.83
Water (Lt/m ³)	160	140
w/c	0.38	0.30
S.P 1,5% (lt/m ³)	6.228	9.28
Fine Aggregate (Kg/m ³)	696.62	662.07
Coarse Aggregate (Kg/m ³)	1044.93	1080.22

2.2 Test Specimens and Instrumentation

The main objective of the experimental program was to generate data on inelastic moment-curvature relationships for column with different parameters, to be consequently compared with the computed response. The experimental research consisted of 12 square short columns with different parameters of confinement and eccentricity of loading. Two of these did not have reinforcement in the test region (specimen KKE1 and KKE2). All had cross-sectional dimensions of 120x120 mm in the test region. To assure that failure would occur in the test region, the end blocks of all the specimens were designed to have flexural and shear strengths well in excess of the loads applied in the test.

Two different concrete compressive strength, two different of tie spacing and confining reinforcement ratio, and two levels of end eccentricity were considered as test variables. The tie reinforcement diameter is 5.5 mm (undeformed bars) and longitudinal diameter is 10 mm (deformed bars). The selected levels of end eccentricity resulted in e/h ratios

of 0.21 and 0.42. Table 2 provide details of the test specimens.

Columns were tested under monotonically increasing axial compression with constant end eccentricity, using Universal Testing Machine have 1000 kN capacities, and the testing system is displacement control. The load was increased until a significant strength decay was recorded, indicating failure. Linear variable differential transducers (LVDT) were mounted at column midheight on the compression and tension faces to measure the average curvature in the test region. Two electrical strain gauges were installed at confining and longitudinal reinforcement for each column. A Data Loger acquisition system was used to record the data. Figure 1 shows the test specimen test set-up of columns.

Table 2. Properties of Test Specimens

Specimen	f_c' (MPa)	e/h	Confining Reinforcement		Longitudinal Reinforcement
			ϕ (mm)	Ratio (%)	
KKE1	72	-	-	-	-
KE1		0	5.5	3.35	4 D 10
KE2		0.21		3.35	
KE3		0.42		3.35	
KE4		0.21		1.68	
KE5		0.42		3.35	6 D 10
KKE2	51.7	-	-	-	-
KE6		0	5.5	3.35	4 D 10
KE7		0.21		3.35	
KE8		0.42		3.35	
KE9		0.21		1.68	
KE10		0.42		3.35	6 D 10

2.3 Test Results

Test results from experimental investigation then has implemented in moment-curvature curves. All columns showed similar behaviour up to the peak load. No flexural cracking was observed until the peak load was approached. The unconfined concrete (KKE1 and KKE2) specimens failed suddenly in a explosive manner. The specimens failed by crushing in the most compressed fibers near the compression face, followed by the development of failures planes where large pieces of concrete were thrown from the test region.

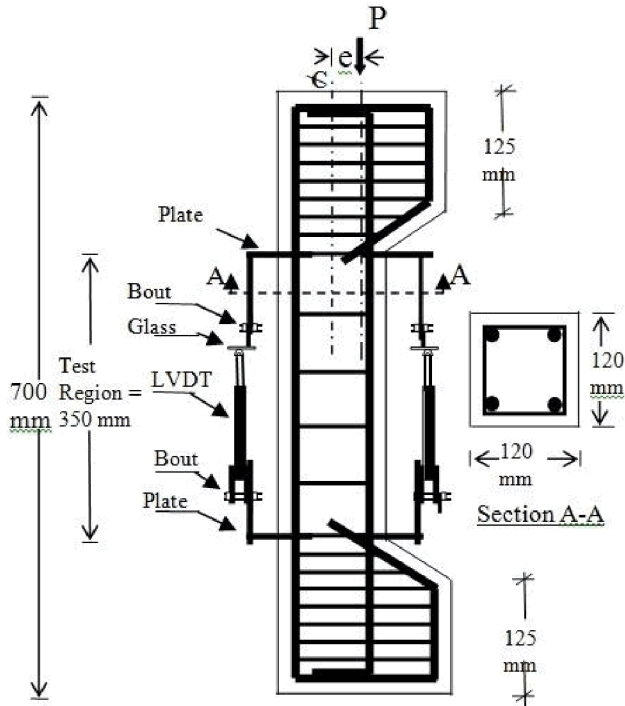

Figure 1. Detail of column specimens.

Figures 2, 3 and 4 showed the comparative of moment-curvatures relationship for the specimens considered the different compressive strength on each of the curve. Columns with lower strength concrete ($f'_c = 51.5$ MPa) showed more ductile behaviour than higher strength concrete ($f'_c = 72$ MPa). The descending branch on the moment-curvature curves tends steeper for higher strength concrete.

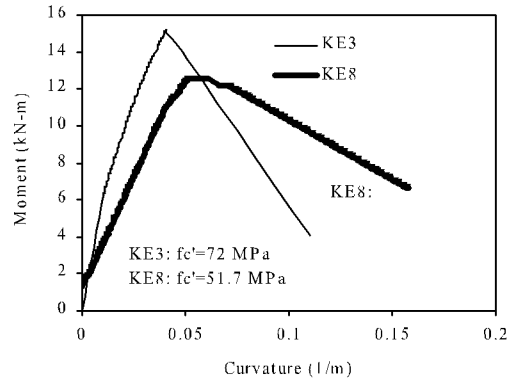

Figure 3. Effect of concrete compressive strength; specimen KE3 vs KE8.

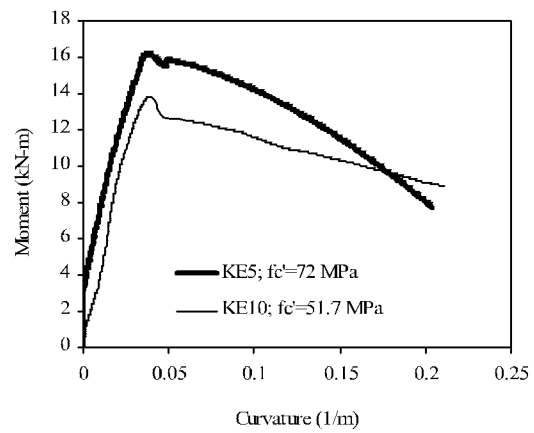

Figure 4. Effect of concrete compressive strength; specimen KE5 vs KE10.

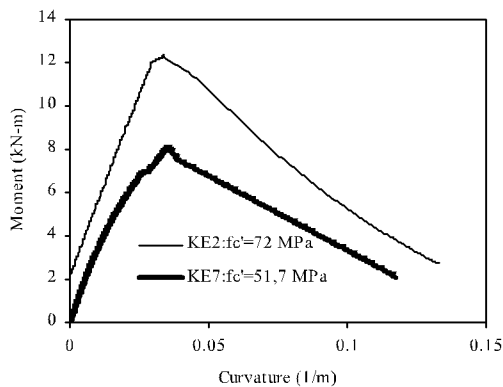

Figure 2. Effect of concrete compressive strength; specimen KE2 vs KE7.

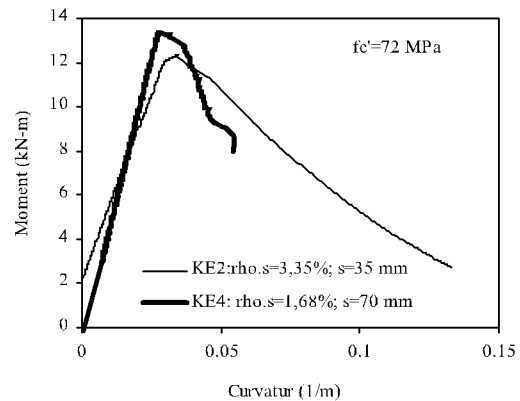

Figure 5. Effect of volumetric ratio; specimen KE2 vs KE4.

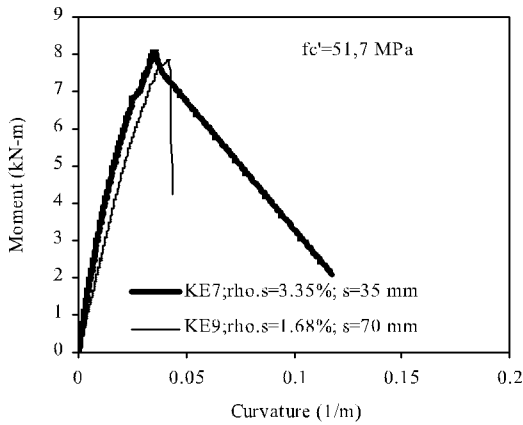

Figure 6. Effect of volumetric ratio; specimen KE7 vs KE9.

Figures 5 and 6 illustrates the influence of volumetric confining reinforcement ratio (3.35% and 1.68% volumetric ratio) on the specimens. The results indicate and extremely ductile response for both column comparisons. When the volumetric ratio improvement to influence the more ductility behaviour or well confined of the columns.

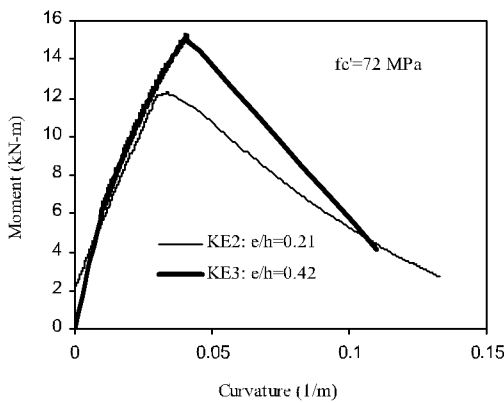

Figure 7. Effect of end eccentricity; specimen KE2 vs KE3.

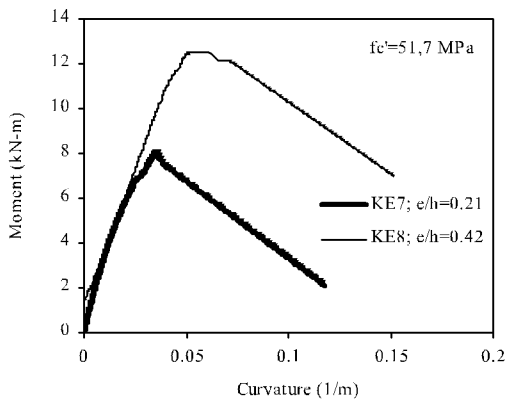

Figure 8. Effect of end eccentricity; specimen KE7 vs KE8.

Influence of end of eccentricity on the specimens showed in the figures 7 and 8. Less capacity and

ductility behaviour of columns if the ratio of the eccentricity to height of columns (e/h) was higher. Same behaviour the specimens on the columns of the concrete compressive stress are 51.7 and 72 MPa.

3 ANALYTICAL MODEL FOR CONFINED CONCRETE

Figure 9 is an idealization of stress-strain model of analytical model for confined concrete have developed by author (2001). The model was established based on a large volume of test data from concentrically tested columns.

The curve of ascending branch expressed below:

$$f_c = \frac{f'_{cc} \left(\frac{\epsilon_c}{\epsilon'_{cc}} \right)^r}{r - 1 + \left(\frac{\epsilon_c}{\epsilon'_{cc}} \right)^r} \tag{1}$$

where $r = \frac{E_c}{E_c - (f'_{cc} / \epsilon'_{cc})}$ (2)

and $E_c = 3400\sqrt{f'_{cc}} + 4800$ (3)

The curve of (*descending branch*) :

$$f_c = f'_{cc} - (\epsilon_c - \epsilon'_{cc}) \frac{0.15 \cdot f'_{cc}}{(\epsilon_{85c} - \epsilon'_{cc})} \tag{4}$$

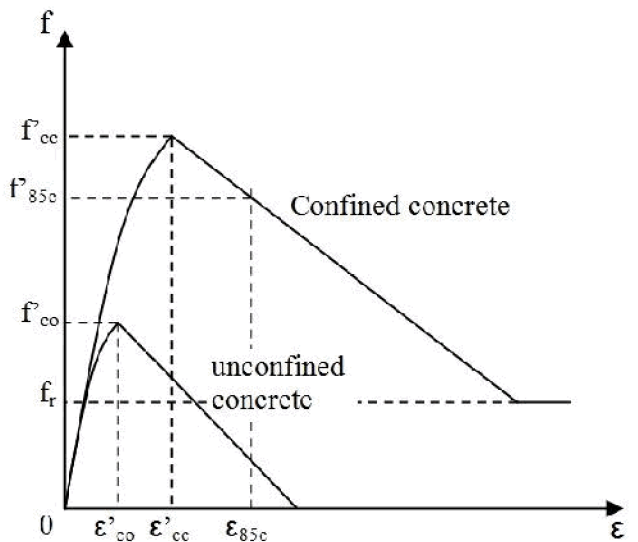

Figure 9. Stress-strain model of confined concrete

The value of strength enhancement of confined concrete ($K=f'_{cc}/f'_{co}$) is given below:

$$K = \frac{f'_{cc}}{f'_{co}} = 1 + 3.7 \left(\frac{f'_{lat.}}{f'_{co}} \right)^{0.9} \tag{5}$$

The strain of confined concrete at peak stress is:

$$\epsilon'_{cc} = \epsilon'_{co} [1.94(K - 1) + 1] \tag{6}$$

where

$$\epsilon_{co}' = 0,0004 \cdot (f'_{co})^{0.45} \tag{7}$$

Stress of confining reinforcement at peak response can be predicted based on equation below (for square section):

$$f_s = E_s \left\{ 0,0004 \cdot \ln \left[\frac{\left(\frac{s}{D_c} \right)}{\rho_s \sqrt{f'_c}} \right] + 0,002 \right\} \leq f_y \tag{8}$$

Strain at 85% strength level beyond the peak:

$$\epsilon_{85c} = \epsilon_{cc}' + 10^{-5} \cdot e^{3.7K} \tag{9}$$

And the residual stress:

$$f_r = 0,25 f'_{cc} \tag{10}$$

4 CORROBORATION WITH EXPERIMENTAL RESULTS

The analytical model for confined concrete was proposed is then used to simulate experimental results of high-strength concrete subjected eccentric loading. Two different of concrete compressive strength from the experimental test used to compared with the model, they are specimen KE2 and KE5 (72 MPa) and KE8 and KE10 (51.7 MPa). The results of the analysis along with their experimental counterparts are plotted in figures below. It is seen from the figures that the model simulates successfully the trends of the moment-curvatures relationship.

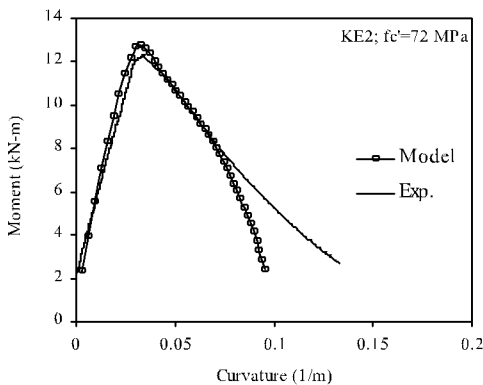

Figure 10. Model vs Experiment; Specimen KE2.

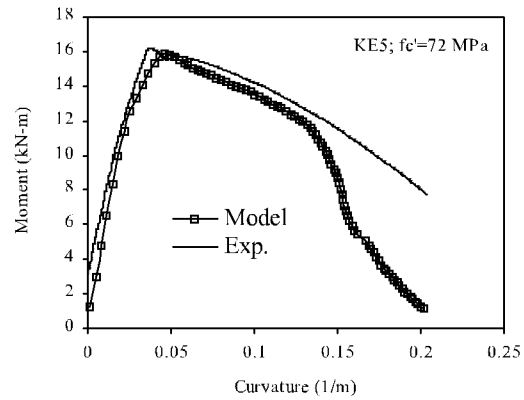

Figure 11. Model vs Experiment; Specimen KE5.

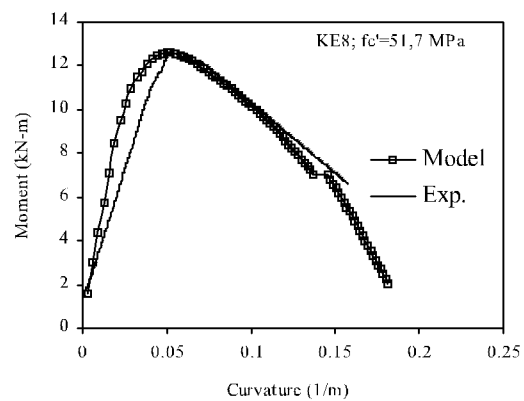

Figure 12. Model vs Experiment; Specimen KE8.

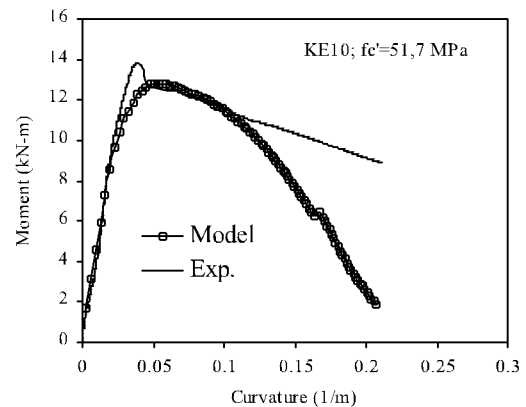

Figure 13. Model vs Experiment; Specimen KE10.

5 CONCLUDING REMARKS

The following conclusions can be drawn from studies and experimental results in this paper.

- a) The ductility of reinforced concrete columns is dependent on the confinement provided by the lateral reinforcement (i.e. concrete compressive strength, volumetric ratio).
- b) Strength enhancement of concrete tends less of ductility and more brittle failure.

- c) The end of eccentric loading has important role on the ductility behaviour of reinforced concrete columns, where a brittle failure occur on the higher the end of eccentricities.
- d) The model has been proposed shows good correlations with moment-curvature relationships established experimentally.

ACKNOWLEDGMENTS

The experimental program presented in this paper was funded by Directorate General of Higher Education, Ministry of National Education, Republic of Indonesia through the Competitive Research Program. The support received for this research successfully is gratefully acknowledged.

REFERENCES

- Antonius (2001). "Behaviour of Reinforced High-Strength Concrete Columns under Concentric and Eccentric Axial Loads". *Disertation*, Institut Teknologi Bandung (in Indonesian).
- Indonesian National Standard (2002); *Computational Method of Reinforced Concrete Structures for Building*; SNI-03-2847-2002 (in Indonesian).
- Foster, S.J. and Attard, M.M. (1997). "Experimental Tests on Eccentrically Loaded High-Strength Concrete Columns". *ACI Structural Journal*, V.94, No.3, May-June 1997, 295-303.
- Ibrahim, H.H.H. and MacGregor, J.G. (1996). "Tests of Eccentrically Loaded High-Strength Concrete Columns". *ACI Structural Journal*, V.93, No.5, Sept.-Oct. 1996, 585-594.
- Legeron, F. and Paultre, P. (2000). "Behavior of High-Strength Concrete Columns under Cyclic Flexure and Constant Axial Load". *ACI Structural Journal*, V.97, No.4, July-August 2000, 591-601.

Lloyd, N.A. and Rangan, B. Vijaya (1996). "Studies on High-Strength Concrete Columns under Eccentric Compression". *ACI Structural Journal*, V.93, No.6, Nov.-Dec. 1996, 631-638.

Mostafaei, H; Vecchio, F.J. and Kabeyasawa, T. (2009). "Deformation Capacity of Reinforced Concrete Columns". *ACI Structural Journal*, V.106, No.2, March-April, 187-195.

Saatcioglu, M., Salamat, A.H. and Razvi, S. (1995). "Confined Columns under Eccentric Loading". *Journal of Structural Eng. ASCE*, V.121, No.11, November 1995, 1547-1556.

Tan, Teng-Hooi and Nguyen, Ngoo-Ba (2005). "Flexural Behavior of Confined High-Strength Concrete Columns". *ACI Structural Journal*, V.102, No.2, March-April, 198-205.

NOTATIONS

- D_c = core diameter of confined concrete (c.t.c)
 E = concrete modulus of elasticity
 f_{co}' = peak stress of unconfined concrete
 f_c' = cylinder concrete compressive stress at 28 days
 f = stress of concrete
 f_{cc}' = peak stress of confined concrete
 f_{lat} = lateral stress
 f_r = residual stress of confined concrete
 f_r = stress of confining reinforcement
 K = strength enhancement of confined concrete
 s = space of ties (confining reinforcement), c.t.c
 ϵ_c = strain of concrete
 ϵ_{85c} = strain of confined concrete at 85% of confined concrete peak stress
 ϵ_{co}' = peak strain of unconfined concrete
 ϵ_{cc}' = peak strain on confined concrete
 ρ_s = ratio of confining reinforcement